

Switching actuator, 1 x 16 A

UP 511S32



Switching actuator UP 511S32 is used as a combination device with binary inputs and a switching output for switching electrical consumers in building automation. Device control is conducted via KNX.

- Switching actuator with one relay contact for AC 230 V, 16 A, for switching electrical consumers
- 3 binary inputs for potential-free contacts to determine the switching state when conventional buttons, switches, windows/door contacts or corresponding sensors are connected
- Flexible installation concept with flush-mounting installation as main installation type and additional installation on a mounting rail in the electrical distributor or surface mounting in false ceilings, parapet ducts, and floor tanks using a mounting case.

Functions for configuration with ETS:

- Encrypted telegram transmission via KNX Data Secure
- Flexible and powerful applications with binary inputs and switch output in one device
- Switching and monitoring function on the output, with ON/OFF switch delay, staircase function, scene control, logic operation, blocking function, forced control

Characteristics

The switching actuator receives telegrams from sensors or other controllers via the KNX and switches an electrical consumer. Functional features include opener or closer operation, extensive time functions, logic operations, scenes, monitoring functions, operating hours counter, blocking function and forced control. In addition, the switching status of a relay output can be reported back. Central switching of the switching outputs via up to 6 central functions is also possible in switching mode.

Aside from the relay output, the device has 3 additional inputs. Potential-free switches, pushbuttons or other contacts (e.g. magnetic contacts) can be connected to these inputs. The signals of the inputs are read in via a common reference potential at the device. Depending on how the ETS is configured in the application for switches, pushbuttons or contacts, inputs 1 and 2 either act internally on the relay output or separately on the KNX bus. Input 3 always acts on the KNX if required. When acting internally, inputs 1 and 2 directly operate the switching output in an adjustable configuration. When acting on the KNX, telegrams for switching or dimming, for blind control or value transmitter application (dimming value transmitter, light scene extension unit, color or color temperature value transmitter) can be sent individually from the inputs.

In addition to the switching mode and the inputs, the device has 8 internal logic functions for realizing simple or complex logic operations.

The electronics of the device are supplied via the bus voltage (no additional supply voltage required).

The screw terminals on the device are designed for connecting untreated solid conductors, flexible conductors without ferrules 0.5 to 4 mm² and flexible conductors with ferrules 0.5 to 2.5 mm². The KNX connection and the 3 binary inputs are connected via a preassembled control line YY6x0.6.

The device is designed for installation in suitable device boxes (recommendation: electronic device box with partition).

The device is KNX Data Secure-enabled. KNX Data Secure protects the building automation systems against manipulation and can be configured in the ETS project. For secure commissioning, it is mandatory that a device certificate be affixed to the device. As part of the installation process, the device certificate must be removed from the device and kept in a safe place.

The device can be updated. Firmware updates can be conveniently installed via the Siemens firmware download tool.

Functions

Building site function

The factory settings allow the output to be operated via a switch on input 1 (ON/OFF). Inputs 2 and 3 have no function.

Programming mode

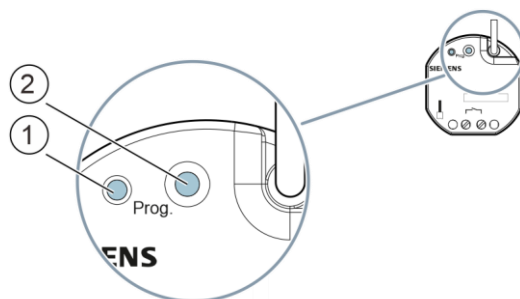

Fig. 1: Programming button and programming LED (exemplary illustration)



After bus voltage recovery, wait several seconds before pushing the programming button (2) (not until booting is complete).

Activate programming mode

- a) Briefly press the programming button (2) (< 1 s).
- ⇒ Programming mode is activated.
- ⇒ The programming LED (1) illuminates continuously.

Deactivating programming mode

- ✓ Programming mode is activated. The programming LED (1) illuminates continuously.
- a) Briefly press the programming button (2) (< 1 s).
- ⇒ Programming mode is deactivated.
- ⇒ The programming LED (1) is not illuminated.

Behavior on bus voltage failure/recovery

In the event of a bus voltage failure, the current status and other values for each input and the switching contact are permanently saved so that they can be restored when the bus voltage is recovered.

When bus voltage is recovered, the configured actions for each input and the switching output are configured and, depending on the parameters set, new statuses are reported.

Binary inputs

- Depending on how the ETS is configured in the application for switches, pushbuttons or contacts, inputs 1 and 2 either act internally on the relay output or separately on the KNX bus. Input 3 always acts on the KNX if required.
- Individually adjustable functions for the inputs with effect on the KNX (switching, dimming, shutter, value transmitter, scene extension unit, 2-channel operation, controller extension unit, no function)
- Switching: Command when closing and opening the contact adjustable (no reaction, ON, OFF, TURN). The behavior after bus voltage recovery can be preset.
- Dimming: Dimming of brightness and/or color temperature. Command when closing the contact, time between switching and dimming, dimming in different steps, telegram repetition in case of long signal at the input and sending of a stop telegram at the end of the dimming process configurable, presetting of the behavior after bus voltage recovery possible.
- Shutter: The command when closing the contact and operating concept is configurable. Times for short and long signal at input and slat adjustment adjustable, behavior after bus voltage recovery can be preset.
- Value transmitter: Can function as 1-byte, 2-byte, 3-byte or 6-byte value transmitter incl. color temperature and color value transmitter; individually configurable values, optional value adjustment with long signal at input (not with 6-byte value transmitter) and presetting of behavior after bus voltage recovery is possible.
- Scene extension unit: Adjustable function (without or with memory function) and the scene number
- 2-channel operation: When closing the contact on the input, up to two telegrams can be sent to the KNX. Adjustable operating concept (channel 1 only or channel 2/both channels). The functions of the channels (1-bit, 1-byte, 2-byte, 3-byte, 6-byte) can be configured separately.
- Controller extension: Configurable functions (operating mode switching, forced operating mode switching, presence function and setpoint shift)
- Blocking of all or individual inputs via a 1-bit object possible, polarity of the blocking object, behavior at the beginning and end of the blocking and behavior during an active blocking adjustable

Switch output

- Independent switching of the switching output
- Normally open or normally closed operation
- Central switching function via up to 6 switching objects (ON, OFF, permanently ON, permanently OFF)
- Switching response: active (sending on change or cyclically to the bus) or passive (object can be read) response function
- Adjustable reaction on bus voltage failure/recovery and after an ETS programming operation
- Logical link function
- Configurable blocking function, alternatively, configurable forced position function
- Time functions (switch-on, switch-off delay, staircase lighting function - also with pre-warning function)
- Inclusion in lighting scenes possible: up to 64 internal configurable scenes
- Operating hours counter can be activated
- Input monitoring for cyclical update of the switching object with safety position

Logic functions

- The device has 8 internal logic functions in addition to the switching operation and the inputs.
- Logic gates (e.g. AND, OR, exclusive OR, each with up to 4 inputs)
- 1-bit-to-1-byte converter with input filter, blocking object and specification of output values
- Blocking element with filter and time functions and blocking object
- Comparator for values with 9 different input data formats and many comparison operations
- Limit switch with hysteresis with upper and lower threshold value for 9 different input data formats. Incl. setting the 1-bit output values.
- The logic functions have dedicated KNX communication objects and can process telegrams from the actuator or other bus devices.

Position and function of the connections, operating and display elements

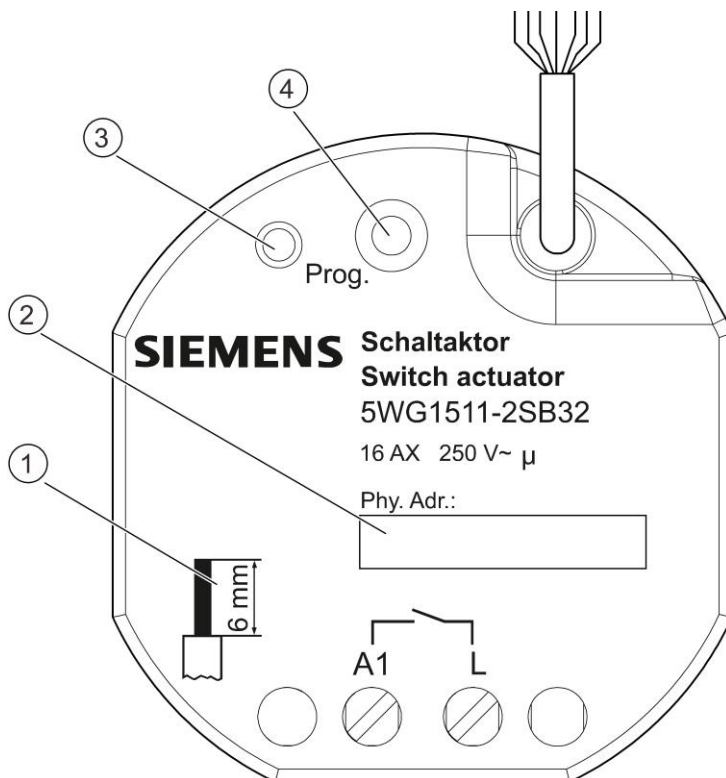

Fig. 2: Connections, operating and display elements

Pos.	Operating or display elements	Function
1	Note on cable insulation	Stripping length 6 mm
2	Label field	Enter physical address
3	Programming LED (red)	LED on = programming mode active
4	Programming button	Short push of button (< 1 s): <ul style="list-style-type: none"> • Activate programming mode, display state (LED on = active)

Type overview

Type	Description	Article number	KNX PL-Link
	Switching actuator UP 511S32, 1 x 16 A	5WG1511-2SB32	No

Version of the Engineering Tool Software

Application	Version
Engineering Tool Software (ETS)	ETS5 version 5.7.3 or higher

Type	Description	Article number
	Mounting case M 592/01	5WG1592-8AB01

Product documentation and support

Product documentation

Documents related the product, such as operating and installation instructions, application program description, product database, additional software and CE declarations can be downloaded from the following website:

<https://www.siemens.com/gamma-td>



Frequently asked questions

For frequently asked questions about the product and their solutions, see:

<https://support.industry.siemens.com/cs/products?dtp=Faq&mf=ps&lc=de-WW>



Support

Contact details for additional questions relating to the product:

Tel.: +49 911 895-7222

Fax: +49 911 895-7223

Email: support.automation@siemens.com

<http://www.siemens.com/supportrequest>



Security

⚠ CAUTION**National safety regulations**

Failure to comply with national safety regulations may result in personal injury and property damage.

- Observe national provisions and comply with the appropriate safety regulations.



⚠ The device should only be installed and put into operation by a certified electrician.

- When connecting the device, ensure that the device can be enabled.
- Do not open the casing of the device.
- Secure the phases with a B16 line protection switch.
- For planning and construction of electric installations, the relevant guidelines, regulations and standards of the respective country are to be considered.
- Do not connect DC or AC voltage to the inputs of the potential-free contacts (as this damages/destroys the device and leads to voltage carry-over to the bus).
- Ensure safe separation from hazardous voltages when connecting the floating contacts.
- Install the device in a location that is inaccessible to non-professionals (e.g. flush-mounted box, sill duct, control cabinet).

Incorrect installation can deactivate electrical safety features without this being apparent to a lay person.



If you pass on the device, ensure you also pass on the documentation for the device, such as, the operating instructions.

NOTICE



Risk of damage to connected drive motors due to incorrect load control by undefined relay state at delivery!

Ensure that all relay contacts are open before switching on the load by applying the KNX bus voltage. Observe the commissioning sequence!

Connecting loads to the switching contact

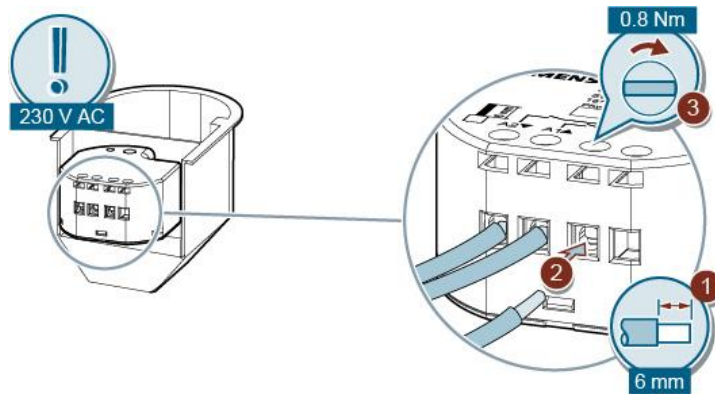
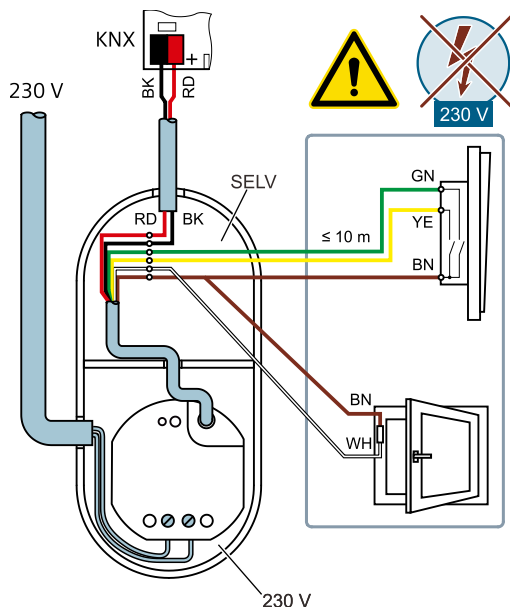

Fig. 3: Connecting loads to the switching contact

Cu		
	0.5 ... 4.0 mm ²	
	0.5 ... 2.5 mm ²	

Connecting the contacts to the binary input and KNX connection



⚠ DANGER!

Never connect mains voltage (230 V) or other external voltages to the extension inputs. Connecting an external voltage jeopardizes the electrical safety of the entire KNX/EIB system (SELV/no galvanic isolation)! Persons may be exposed to danger, equipment and facilities may be destroyed.

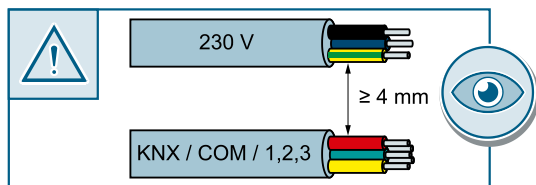

Ensure a distance of at least 4 mm between the low voltage lines (bus and extension inputs) and the load lines (230 V).

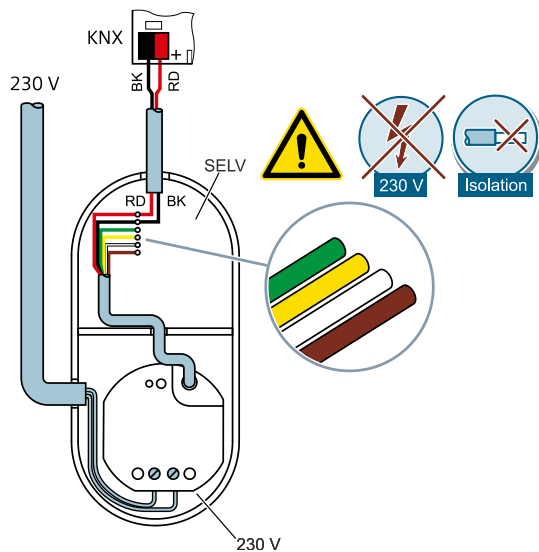

⚠ DANGER!

- Do not insulate any of the wires of the 6 pole connection line against each other and against external voltages.
- Never connect input 1 (green), input 2 (yellow), input 3 (white) or reference potential (com) (brown) to inputs or reference potential (com) of other devices.
- Never place bus/binary input and mains voltage terminals together in a the same connection box. Use a device socket with a rigid partition or separate device sockets (recommendation: electronic device box with partition). Observe cable routing and spacing.

Test of KNX 24 V DC type SELV

This test can be used to check whether the bus connection cable is connected with the correct polarity and whether device is supplied with bus voltage.

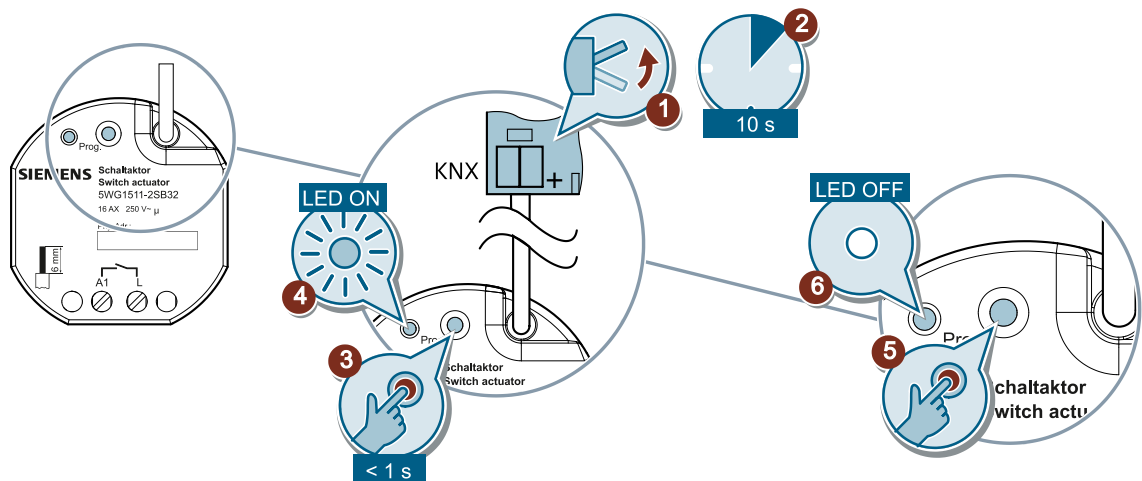

Fig. 4: Test KNX 24 V DC type SELV

Safe-state mode

Safe-state mode stops the execution of the application program that has been loaded.



Only the system software of the device is still running. ETS diagnostic functions and programming of the device are possible

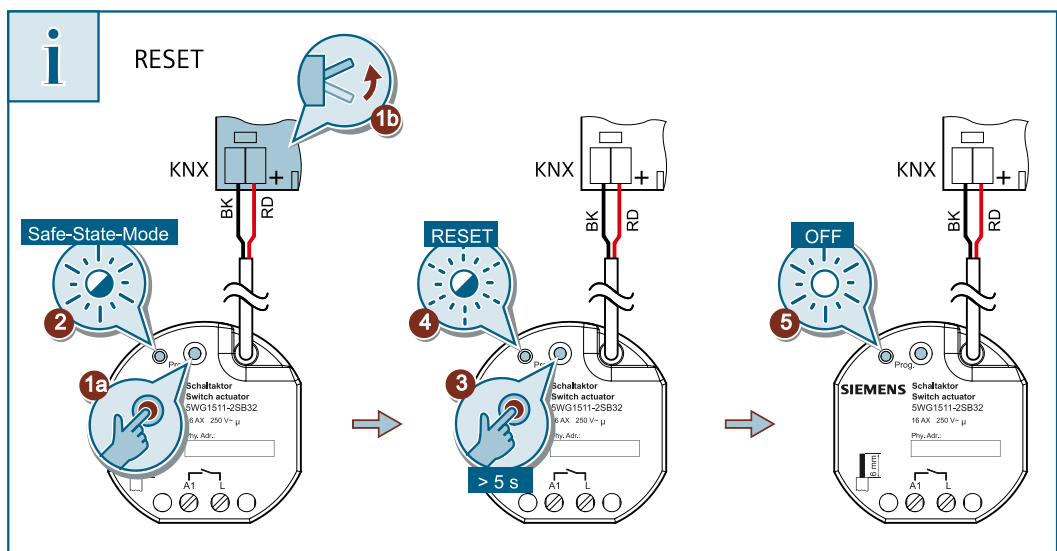

Fig. 5: Execute safe-state mode and master reset

Activate safe-state mode

- a) Switch off bus voltage or disconnect device from the KNX.
- b) Wait approx. 10 s.
- c) Press and hold down the programming button (1a).
- d) Switch on the bus voltage or connect device to KNX (1b).
- e) Release the programming button only once the programming LED is flashing slowly (2).
⇒ Safe-state mode is activated.

Briefly pressing the programming button again switches programming mode on and off just like in safe-state mode. If programming mode is active, the programming LED no longer flashes.

Deactivate safe-state mode

- a) Switch off bus voltage or disconnect device from the KNX.
- b) Wait approx. 10 s or execute ETS programming operation.
 - ⇒ Safe-state mode is deactivated.

Master reset

The master reset resets the device to the original settings (physical address 15.15.255, firmware is left alone). The device must then be restarted with the ETS.

In secure mode: A master reset deactivates the device safety. The device can then be re-commissioned with the device certificate.

Perform master reset

- ✓ Safe-state mode is activated.
- a) Press and hold the programming button for > 5 s (3).
 - ⇒ The programming LED flashes rapidly (4).
- ⇒ The device executes a master reset, restarts and the LED turns off (5).
- ⇒ The device is ready for operation again after approx. 5 s.

Location of the device certificate QR code

The ETS requires the appropriate device certificate for secure commissioning. The device certificate is a string containing the device specific key FDSK (Factory Default Setup Key) and the serial number of a KNX data-secure enabled device. The certificate must be communicated to the ETS.

The FDSK is a factory unique string for each secure device. It is used one time by the ETS to generate additional (digital) keys (tool key/runtime key) for secure communication within the project and saved precisely for this device in the ETS project. If the FDSK is lost, the device cannot be commissioned in secure mode.

When performing a factory reset, the FDSK must be entered in the project again for secure commissioning.

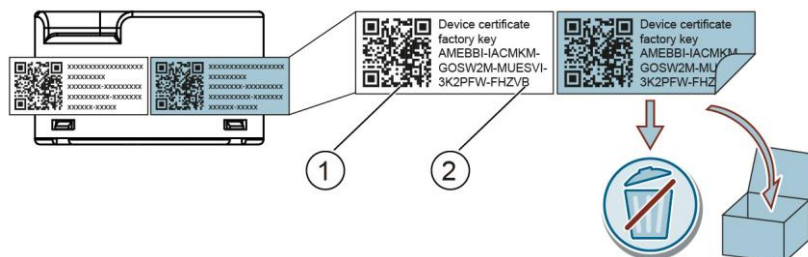

Fig. 6: Device certificate

Pos.	Description
1	QR code
2	Factory key

The device certificate is affixed to the side of the device. An extra copy of the device certificate is provided so that it can be removed for secure commissioning with the ETS and then kept in a safe place.



The device certificate is to be removed from the device and stored in a safe place! The FDSK must not fall into the hands of unauthorized parties!

Disposal



The device is considered an electronic device for disposal in accordance with European Directive and may not be disposed of as domestic waste.

- ▲ Use only designated channels for disposing the devices.
- Comply with all local and currently applicable laws and regulations.

Power supply

Power supply	
Rated voltage KNX	DC 24 V (DC 21... 30 V)
Power consumption KNX	5 ... 18 mA
Power loss (internal consumption)	150 mW

Inputs

Binary inputs	
Number of inputs	3
Control lead (pre-assembled)	YY6x0.6
Input type	potential free
Pulse voltage if contact is open	5 V
Pulse current if contact is closed	Continuously 1.5 mA
Total length of extension input lead with pairs of twisted cables	max. 10 m
Lead type (preferred)	J-Y(St)Y
Input signal delay until first bus telegram after closing the contact	approx. 15 ms + debounce time (configurable)
Input signal delay until first bus telegram after opening the contact	approx. 15 ms + debounce time (configurable)
Debounce time (configurable), min. (= from)	30 ms
Debounce time (configurable), max. (= to)	255 ms

Outputs

Switching outputs	
Number of load relays (bi-stable relays, potential-free)	1
Switching voltage (at 50/60 Hz)	AC 250 V
Rated current per channel	16 AX
Switching cycle for each device	16 A

Contact current	
Inrush current 200 µs	800 A
Inrush current 20 ms	165 A
Rated current AC1 operation (cos phi = 0.8)	10 A
Maximum capacitive load	16 A
Rated current AX capacitive load (35 µF)	16 A

Contact current	
Rated current AX capacitive load (70 µF)	16 A
Rated current AX capacitive load (140 µF)	16 A
Restrictions for rated current (device) – derating information	Reduction of connected load per 5 °C exceedance of 35 °C -10 % when installed in wood or drywall -15 % for installation in multiple combinations -20 %

Switching capacity/load types	
Switching capacity, current	16 AX
Maximum switching capacity at rated value	2500 W
Multi-phase operation	No
Switching capacity active power / of make contacts of relay outputs / maximal	2500 W
Switching capacity, current of contacts at maximum resistive load	2500 W
Maximum capacity per output	2500 W
Rated output at AC3	Motors 1380 VA
Switching of capacitive loads (C load)	16 A (140 µF)
Rated output with load type from incandescent lamps	2300 W
Rated output with load type from HV halogen lamps	2300 W
Rated output with load type from HV LED lamps	400 W (230 V)
Rated output with load type from LV halogen lamps with electronic transformers	1500 W
Rated output with load type from LV halogen lamps with magnetic transformers	1200 VA
Rated output with load type from compact fluorescent lamps, uncompensated	1000 W
Rated output with load type from compact fluorescent lamps, parallel-compensated	1160 W (140 µF)

Reliability

Failure rate	
Failure rate (at 40°C)	245 fit

Service life

Service life	
Mechanical service life (switch cycles in millions)	3

Connection types

Clampable conductor cross-sections	
solid	0.5 ... 4 mm ²
fine stranded without ferrule	0.5 ... 4 mm ²
fine stranded with ferrule	0.5 ... 2.5 mm ²
Tightening torque screw terminals	max. 0.8 Nm

Mechanical data

Mechanical data	
Material housing	PC
Housing width	48 mm
Housing length	50 mm
Housing height	28 mm
Product weight	52 g
Fire load	0.55 kWh (2 MJ)

Environmental conditions

Ambient conditions	
Environmental category (as per EN 60721-3-3)	3k5
Ambient temperature	-5 ... +45 °C
Storage/transport temperature	-25 ... +70 °C
Relative humidity (non-condensing)	5 % ... 93 %

Protection settings

Protection settings	
Degree of pollution (according to IEC 60664-1)	2
Overvoltage category (according to IEC 60664-1)	3
Protection type IP	20
Electrical safety, bus	Yes
Electrical safety, device complies with	EN 50428
EMC requirements, device complies with	EN 50428

Test mark

Test mark	
CE marking	Yes
KNX approval mark	Yes

Test mark	
EAC marking	Yes
RCM marking	Yes
UKCA marking	Yes

Connection example

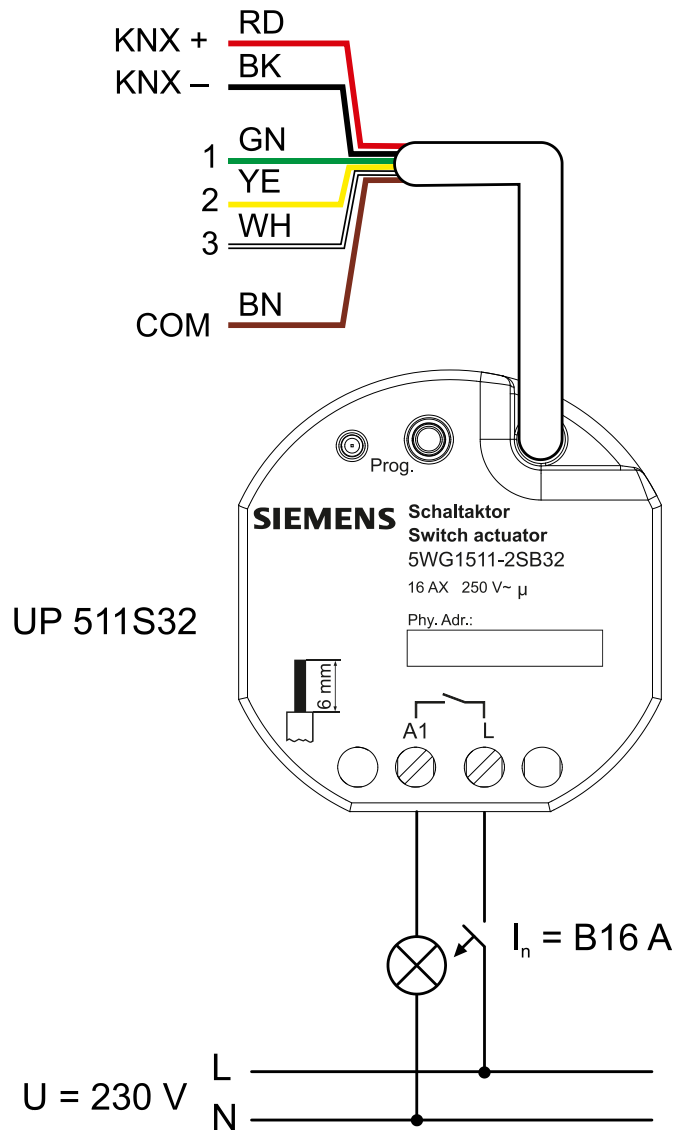

Fig. 7: Connection example for switching output

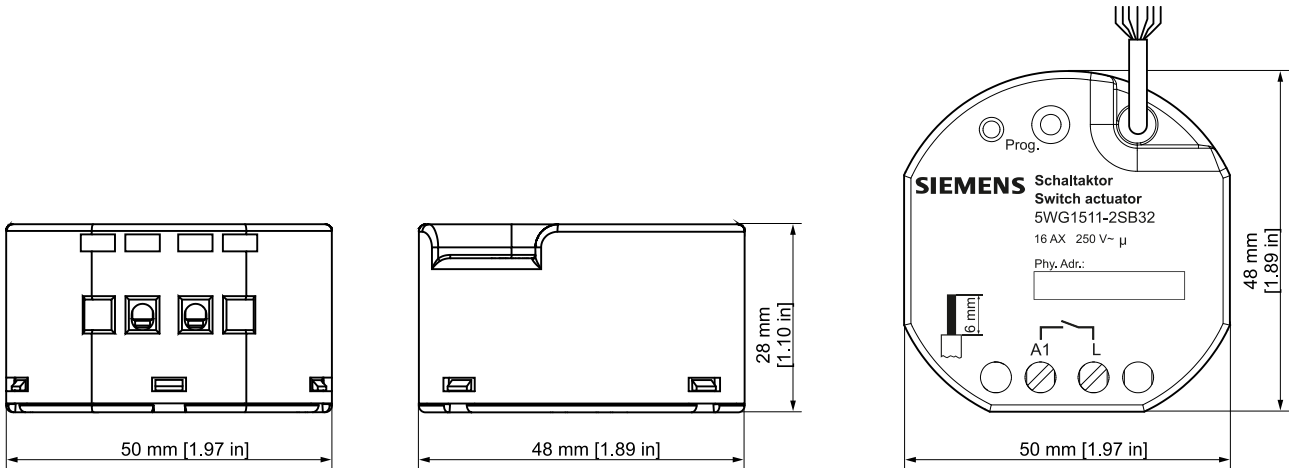

Fig. 8: Dimensions

Issued by
Siemens Switzerland Ltd
Smart Infrastructure
Global Headquarters
Theilerstrasse 1a
CH-6300 Zug
+41 58 724 2424
www.siemens.com/buildingtechnologies

© Siemens Switzerland Ltd, 2021
Technical specifications and availability subject to change without notice.