



Basic Unit with integrated Fuel / Air Ratio Control for Forced Draft Burners LMV27.100...

The LMV27 burner management system is a microprocessor-based burner control with matching system components for control and supervision of forced draft burners of medium to high capacity.

The LMV27 and this Data Sheet are intended for use by OEMs which integrate the actuators in their products!

Use

Microprocessor-controlled LMV27 for single-fuel burners of any capacity in intermittent operation, with electronic fuel-air ratio control, with up to 2 actuators, and with integrated gas valve proving.

The system components (AZL2 and actuators) are connected directly to the LMV27. All safety-related digital inputs and outputs of the LMV27 are supervised by a contact feedback network.

- Type-tested and approved in accordance with DIN EN 298
- Applications in accordance with EN 676: Automatic forced draft burners for gaseous fuels
- Applications in accordance with EN 267: Forced draft burners for liquid fuels

For Europe

For intermittent operation in connection with the LMV27, the ionization probe or the QRA, QRB or QRC optical flame detector can be used.

For North America

For intermittent operation in connection with the LMV27, the ionization probe or the optical flame detector QRA4 can be used.

Features

The following components are integrated in the LMV27:

- Burner control complete with valve proving system
- Electronic fuel / air ratio control system for a maximum of 2 actuators SQM3 or SQN1
- Modbus interface
- BCI for connection a display or PC
- Unit parameter adjustable either via display or PC software ACS410

Notes



Warning!

All safety, warning and technical notes given in the Basic Documentation of the LMV27 (P7541) also apply to this document!



Applied directives:

- Low-voltage directive 2014/35/EC
- Directive for pressure devices 2014/68/EU
- Gas Appliances Regulation (EU) 2016/426
- Electromagnetic compatibility EMC (immunity) *) 2014/30/EC

*) The compliance with EMC emission requirements must be checked after the burner management system is installed in equipment

Compliance with the regulations of the applied directives is verified by the adherence to the following standards / regulations:

- Automatic burner control systems for burners and appliances burning gaseous or liquid fuels DIN EN 298
- Safety and control devices for gas burners and gas burning appliances - Valve proving systems for automatic shut-off valves DIN EN 1643
- Gas/air ratio controls for gas burners and gas burning appliances - Part 2: Electronic types DIN EN 12067-2
- Safety and control devices for burners and appliances burning gaseous and/or liquid fuels — General requirements DIN EN 13611
- Safety and control devices for gas burners and gas-burning appliances - Particular requirements Part 1: Automatic and semi-automatic valves ISO 23552-1
- Automatic electrical controls for household and similar use Part 2-5: Particular requirements for automatic electrical burner control systems DIN EN 60730-2-5

The relevant valid edition of the standards can be found in the declaration of conformity!



Note on EN 60335-2-102

Household and similar electrical appliances - Safety - Part 2-102: Particular requirements for gas, oil and solid-fuel burning appliances having electrical connections. The electrical connections of the LMV27 comply with the requirements of EN 60335-2-102.



EAC Conformity mark (Eurasian Conformity mark)



ISO 9001:2015
ISO 14001:2015
OHSAS 18001:2007



China RoHS
Hazardous substances table:
<http://www.siemens.com/download?A6V10883536>



Life cycle

The burner management system LMV27 has a designed lifetime* of 250,000 burner startup cycles which, under normal operating conditions in heating mode, correspond to approx. 10 years of usage (starting from the production date given on the type field). This lifetime is based on the endurance tests specified in standard DIN EN 298. A summary of the conditions has been published by the European Control Manufacturers Association (Afecor) (www.afecor.org).

The designed lifetime is based on use of the LMV27 according to the manufacturer's Data Sheet and Basic Documentation. After reaching the designed lifetime in terms of the number of burner startup cycles, or the respective time of usage, the LMV27 is to be replaced by authorized personnel.

* The designed lifetime is not the warranty time specified in the Terms of Delivery

Supplementary documentation

User documentation Modbus AZL2	A7541
Environmental product declaration LMV2 / LMV3.....	E7541 *)
Installation and operating instructions PC software ACS410.....	J7352
Basic documentation LMV27	P7541
Product range overview LMV2 / LMV3	Q7541

*) On request

System overview

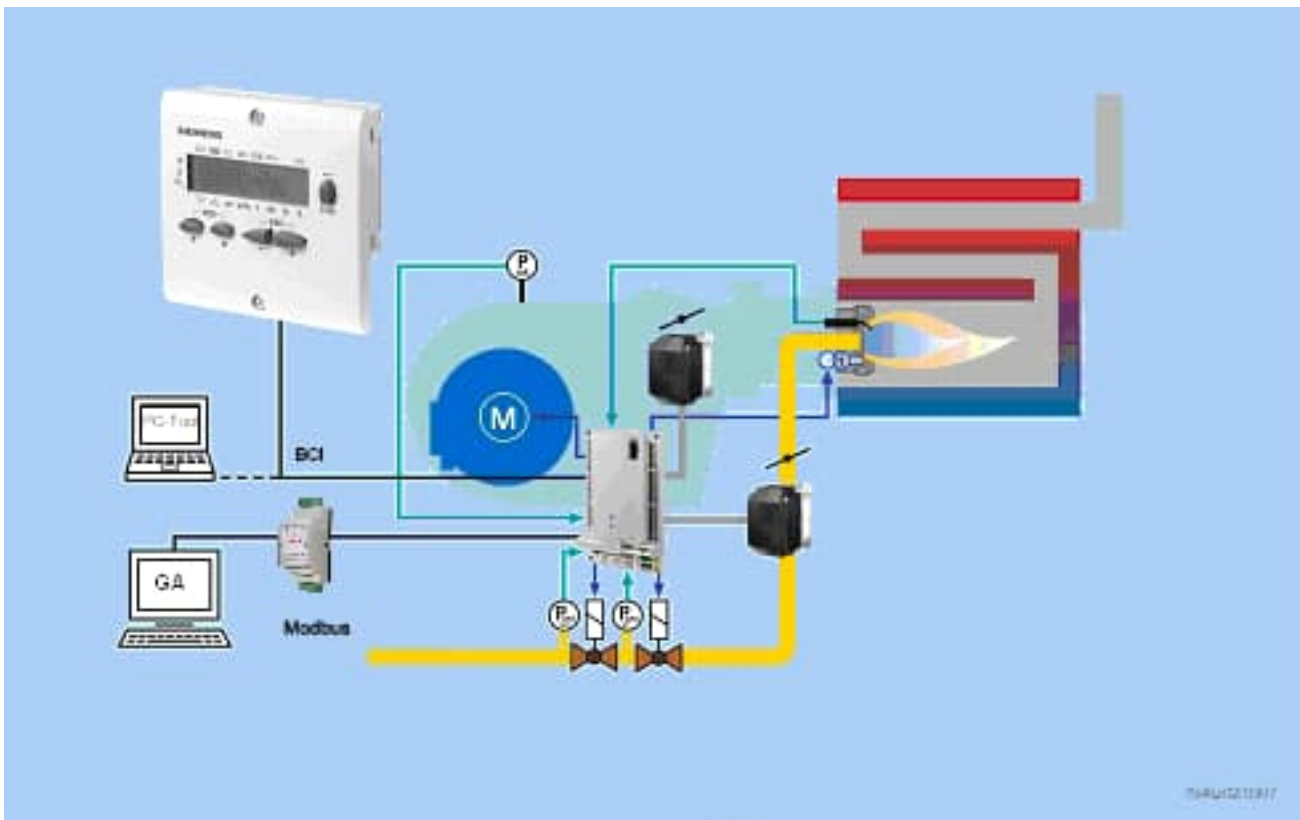

The diagram shows the full scope of functions of the LMV27. The actual functions are to be determined based on the respective execution / configuration!

Ordering

Burner control

LMV27

The basic unit is the actual burner control featuring all-polar input / output terminals. No operating elements. Operation via detached ancillary units for wire-bound communication. See Basic Documentation P7541



Article no.	Type	Mains voltage	Parameter set	Detectors	TSA	
					Gas	Oil
BPZ:LMV27.100A2	LMV27.100A2	AC 230 V	Europa	QRA2/QRA4/ QRA10/QRB/ QRC/ION	3 s	5 s

Service tools

OCI410 interface between burner management system and PC

Article no.: **BPZ:OCI410**

Facilitates viewing, handling and recording setting parameters on site with the help of the ACS410 software package.

See Data Sheet N7616



OCI412.10 Modbus interface

Article no.: **BPZ:OCI412.10**

Device serving as an interface between the LMV27 and a Modbus system, such as a building automation and control system (BACS). The Modbus interface is based on the RS-485 standard.

See Data Sheet N7615



ACS410 PC software

Article no.: **BPZ:ACS410**

PC software for parameterization and visualization to the burner management system.

See Software Documentation J7352

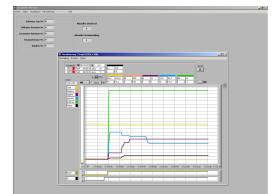

Display and operating units

AZL21.00A9

Article no.: **BPZ:AZL21.00A9**

Detached display and operating unit, choice of mounting methods, 8-digit LCD, 5 buttons, BCI for LMV27, degree of protection IP40.

See Data Sheet N7542



AZL23.00A9

Article no.: **BPZ:AZL23.00A9**

Detached display and operating unit, choice of mounting methods, 8-digit LCD, 5 buttons, BCI for LMV27, degree of protection IP54.

See Data Sheet N7542



Flame detectors

QRA2

Flame detector for use with Siemens burner controls, for the supervision of gas flames and yellow- / blue-burning oil flames as well as ignition spark checking. Plastic housing, metalized to prevent static charging caused by the air flow from the fan. For direct mounting on the burner. The detectors can be supplied with or without securing flange and clamp. **See Data Sheet N7712**



QRA4

Flame detector for use with Siemens burner controls, for the supervision of gas flames and yellow- or blue-burning oil flames as well as for ignition spark proving. See Data Sheet N7711



QRA10

Flame detector for use with Siemens burner controls, for the supervision of gas flames and yellow- / blue-burning oil flames as well as ignition spark checking. Die-cast aluminum housing with a 1 in. mounting coupling and connection facility for cooling air. The housing of this detector has a bayonet fitting which allows it to be secured either directly to the 1 in. mounting coupling or to the AGG06. The 1 in. mounting coupling can be screwed to a viewing tube or to the AGG07. The Pg cable gland can be removed and replaced, if some other detector cable shall be used. See Data Sheet N7712



QRB1

Photo resistive flame detector for use with Siemens burner controls, for the supervision of oil flames in the visible light spectrum. Especially suited for use with burner controls for small capacity burners in intermittent operation. See Data Sheet N7714



QRB3

Photo resistive flame detector for use with Siemens burner controls, for the supervision of oil flames in the visible light spectrum. Especially suited for use with burner controls for small capacity burners in intermittent operation. See Data Sheet N7714

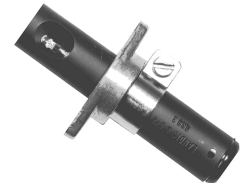

QRB4

Yellow flame detector for use with Siemens burner controls, for the supervision of oil flames in the visible light spectrum. The QRB4 is used in connection with oil burner controls in intermittent operation. Refer to data sheet N7720



QRC

Blue-flame detector for use with Siemens burner controls, for the supervision of blue- or yellow-burning oil or gas flames. Especially suited for use with burner controls for small capacity burners in intermittent operation. See Data Sheet N7716

Frontal illumination



Lateral illumination



Actuators

SQM33.4

Rated torque 1.2 Nm (0.8 Nm holding torque when dead),
running time 5 s, stepper motor, front mounting, D-type drive
shaft.

See Data Sheet N7813

SQM33.5

Rated torque 3 Nm (2.6 Nm holding torque when dead),
running time 5 s, stepper motor, front mounting, D-type drive
shaft.

See Data Sheet N7813



SQM33.7

Rated torque 10 Nm (6 Nm holding torque when dead),
running time 17 s, stepper motor, front mounting, D-type
drive shaft.

See Data Sheet N7813

SQN1

Rated torque 1 Nm (0.2 Nm holding torque when dead),
running time 5 s, stepper motor, front mounting, D-type drive
shaft.

See Data Sheet N7803



Ordering (cont'd)

Connector sets

AGG3.131

Article no.: **BPZ:AGG3.131**

Complete connector set RAST2.5 / RAST3.5 / RAST5 for gas / oil applications, single pack.

See Object List C7541 (74 319 0637 0)

Example: X5-02



AGG3.132

Article no.: **BPZ:AGG3.132**

Complete connector set RAST2.5 / RAST3.5 / RAST5 for gas- / oil applications, pack of 10.

See Object List C7541 (74 319 0637 0)

AGG3.131	AGG3.132	Connector type	Terminal	Description
1	10	RAST5	X3-02	Air pressure switch (LP)
1	10	RAST5	X3-03	Burner flange
1	10	RAST5	X3-04	Power supply (L, N, PE) for safety loop (SK)
1	10	RAST5	X3-05	<ul style="list-style-type: none"> Alarm (AL) Fan motor (M)
1	10	RAST5	X4-02	Ignition (Z)
1	10	RAST5	X5-01	<ul style="list-style-type: none"> Gas pressure switch-min (Pmin) Oil pressure switch-min (Pmin)
1	10	RAST5	X5-02	<ul style="list-style-type: none"> Gas pressure switch-max (Pmax) Oil pressure switch-max (Pmax)
1	10	RAST5	X5-03	External load controller (LR)
1	10	RAST5	X6-03	Safety valve (SV)
1	10	RAST5	X7-01	Fuel valve (V2)
1	10	RAST5	X7-02	Fuel valve (V3)
1	10	RAST5	X8-02	Fuel valve (V1)
1	10	RAST5	X8-04	<ul style="list-style-type: none"> Reset Operating display (B4)
1	10	RAST5	X9-04	<ul style="list-style-type: none"> Gas pressure switch (Pmin/Pmax) Pressure switch valve proving (P LT)
1	10	RAST5	X10-05	Flame detector ION, QRB, QRC
1	10	RAST5	X10-06	Flame detector QRA2/QRA4
1	10	RAST5	X75	Fuel meter
1	10	RAST3.5	X74	1 x 5-pin connector / load output (0/1–10 V)
1	10	RAST3.5	X64	1 x 5-pin connector / reserve
1	10	RAST2.5	X92	Modbus (COM)

AGG9
Single connectors
Packing unit 200 in total

Example X5-03



Article no.	Type	Type of connector	Terminal	Description
BPZ:AGG9.203	AGG9.203	RAST5	X3-02	Air pressure switch (LP)
BPZ:AGG9.204	AGG9.204	RAST5	X3-03	Burner flange
BPZ:AGG9.206	AGG9.206	RAST5	X8-04	<ul style="list-style-type: none"> Reset Operating display
BPZ:AGG9.209	AGG9.209	RAST5	X10-06	Flame detector QRA2/QRA4/QRA10
BPZ:AGG9.217	AGG9.217	RAST5	X75	Fuel meter
BPZ:AGG9.303	AGG9.303	RAST5	X3-05	<ul style="list-style-type: none"> Alarm (AL) Fan motor (M)
BPZ:AGG9.304	AGG9.304	RAST5	X4-02	Ignition (Z)
BPZ:AGG9.306	AGG9.306	RAST5	X5-01	<ul style="list-style-type: none"> Gas pressure switch-min (Pmin) Oil pressure switch-min (Pmin)
BPZ:AGG9.307	AGG9.307	RAST5	X5-02	<ul style="list-style-type: none"> Gas pressure switch-max (Pmax) Oil pressure switch-max (Pmax)
BPZ:AGG9.309	AGG9.309	RAST5	X6-03	Safety valve (SV)
BPZ:AGG9.310	AGG9.310	RAST5	X7-01	Fuel valve (V2)
BPZ:AGG9.311	AGG9.311	RAST5	X7-02	Fuel valve (V3)
BPZ:AGG9.313	AGG9.313	RAST5	X9-04	<ul style="list-style-type: none"> Gas pressure switch (Pmin/Pmax) Pressure switch valve proving (P LT)
BPZ:AGG9.403	AGG9.403	RAST5	X5-03	External load controller (LR)
BPZ:AGG9.406	AGG9.406	RAST5	X8-02	Fuel valve (V1)
BPZ:AGG9.501	AGG9.501	RAST5	X3-04	Power supply (L, N, PE) for safety loop (SK)
BPZ:AGG9.504	AGG9.504	RAST5	X10-05	Flame detector ION, QRB, QRC
BPZ:AGG9.853	AGG9.853	RAST3.5	X64	1 x 5-pin connector / reserve
BPZ:AGG9.853	AGG9.853	RAST3.5	X74	1 x 5-pin connector / load output (0/1–10 V)

Accessories

AGG5.310

Article no.: **BPZ:AGG5.310**

Accessories set speed control, for burner management systems, composed of sensor disk Ø 50, sensor and mounting set.

See Mounting instructions M7550.1 (74 319 9322 0)



Cables

AGV50.100

Article no.: **BPZ:AGV50.100**

Signal cable for AZL2, with RJ11 connector, length 1 m, pack of 10

AGV50.300

Article no.: **BPZ:AGV50.300**

Signal cable for AZL2, with RJ11 connector, length 3 m, pack of 10



Ordering (cont'd)

Proportional controlling element with mounting plate

VKP

Proportional controlling element for mounting between threaded flanges in gas trains.
Refer to Data Sheet N7646.



ASK33.1

Article no.: **BPZ:ASK33.1**

Larger mounting plate required to replace existing mounting plate. Required for mounting the actuators SQM4 or SQM33.

Refer to Data Sheet N7646.



ASK33.2

Article no.: **BPZ:ASK33.2**

Additional mounting plate is required for mounting the actuator SQN13.

Refer to Data Sheet N7646.



Gas damper for mounting kit

VKF41.xxxC

Butterfly valves designed in intermediate flange design, for integration into gas trains.

Refer to Data Sheet N7632.

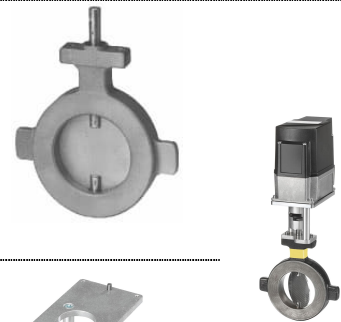

ASK33.4

Article no.: **BPZ:ASK33.4**

Mounting kit for mounting the actuators SQM33.5 on the butterfly valve VKF41.xxxC.

Refer to Data Sheet N7632.



Transformer

A5Q20002669

Article no.: **BPZ:A5Q20002669**

Transformer to increase ionization voltage for AC 120 V devices.

See User Documentation A7541.2.



Connection and internal diagram LMV27

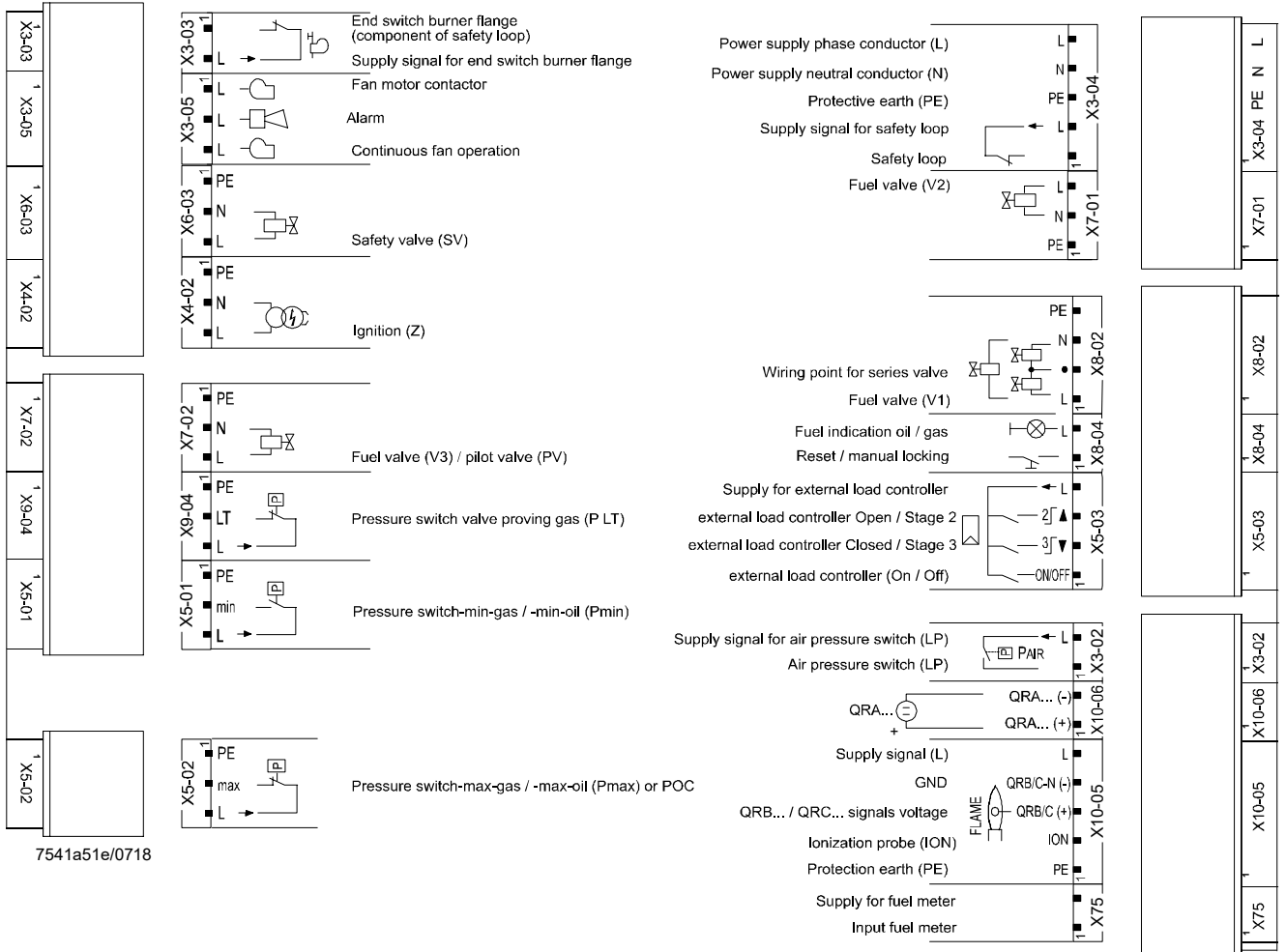

7541a51e/0718

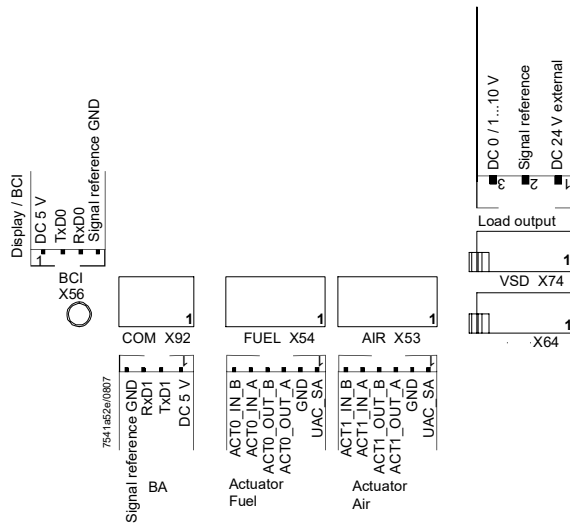

Technical Data

LMV27 basic unit

General

Mains voltage	AC 230 V -15% / +10%
Mains frequency	50 / 60 Hz $\pm 6\%$
Power consumption	<30 W (typically)
Safety class	I with parts according to II and III to EN 60730-1:2016
Degree of protection	IP00 to EN 60529:1991 + A1:2000 + A2:2013



Note

The burner or boiler manufacturer must ensure degree of protection IP40 for LMV27 as per EN 60529:1991 + A1:2000 + A2:2013 through adequate installation.

Mode of operation	Type 2B in accordance with EN 60730-1:2016
Rated surge voltage	In accordance with EN 60730-1:2016, section 20 (OC III)
Voltage and current for the purposes of the EMC emitted interference tests	The emitted interference measurement test takes place with mains voltage and maximum power consumption

Terminal loading «Inputs»

- Permissible primary fuse (Si) (external) Max. 16 AT



Caution!

Risk of damage to the switching contacts!

If the external primary fuse (Si) is blown due to overload or short-circuit at the terminals, the LMV27 must be replaced.

• Unit fuse F1 (internal)	6.3 AT (IEC 60127-2:2014)
• Mains supply: Input current depending on the operating state of the unit	
Undervoltage	
• Safety shutdown from operating position at mains voltage	Approx. AC 186 V
• Restart on rise in mains voltage	Approx. AC 195 V
Status inputs: Status inputs (with the exception of the safety loop) of the contact feedback network (CFN) are used for system supervision and require mains-related input voltage	
• Input safety loop	Refer to <i>Terminal loading outputs</i>
• Input currents and input voltages	
- UeMax	UN +10 %
- UeMin	UN -15 %
- IeMax	1.5 mA peak
- IeMin	0.7 mA peak
• Contact material recommendation for external signal sources (LP, Pmin, Pmax, etc.)	Gold-plated silver contacts
• Transition / settling behavior / bounce	
- Perm. bounce time of contacts when switching on / off	Max. 50 ms (after the bounce time, contact must stay closed or open)
• UN	AC 230 V
• Voltage detection	
- On	AC 180...253 V
- Off	<AC 80 V

Technical Data (cont'd)

Terminal loading
«Outputs»

Total contact loading:

- Rated voltage AC 230 V, 50 / 60 Hz
- Unit input current (safety loop) from: Max. 5 A
 - Fan motor contactor
 - Ignition transformer
 - Fuel valves
 - Oil pump / magnetic clutch

Individual contact loading:

Fan motor contactor

- Rated voltage AC 230 V, 50 / 60 Hz
- Rated current 2 A
- Power factor $\text{Cos}\varphi > 0.4$

Alarm output

- Rated voltage AC 230 V, 50 / 60 Hz
- Rated current 1 A
- Power factor $\text{Cos}\varphi > 0.4$

Ignition transformer

- Rated voltage AC 230 V, 50 / 60 Hz
- Rated current 2 A
- Power factor $\text{Cos}\varphi > 0.2$

Fuel valves

- Rated voltage AC 230 V, 50 / 60 Hz
- Rated current 2 A
- Power factor $\text{Cos}\varphi > 0.4$

Operation display

- Rated voltage AC 230 V, 50 / 60 Hz
- Rated current 0.5 A
- Power factor $\text{Cos}\varphi > 0.4$

Safety valve (magnetic clutch / oil pump)

- Rated voltage AC 230 V, 50 / 60 Hz
- Rated current 2 A
- Power factor $\text{Cos}\varphi > 0.4$

Connections for pressure switch

- Rated voltage AC 230 V, 50 / 60 Hz
- Rated current 1.5 mA
- Power factor ---

Power supply for pressure switch-max / POC (X5-02 pin 3 or X22-02 pin 3)

- I_{aMax} <10 mA

Analog output / load
output X74 pin 3

Accuracy of output voltage $\pm 1 \%$

Technical Data (cont'd)

Cable lengths	• Mains line AC 230 V	Max. 100 m (100 pF/m)
	• Display, BC interface	For installation under the burner hood or in the control panel Max. 3 m (100 pF/m)
	• Load controller X5-03	Max. 20 m (100 pF/m)
	• Safety loop / burner flange (total)	Max. 20 m (100 pF/m)
	• External lockout reset button	Max. 20 m (100 pF/m)
	• Safety valve	Max. 20 m (100 pF/m)
	• Load output ¹⁾	Max. 10 m (100 pF/m)
	• Fuel valve (V1 / V2 / V3)	Max. 3 m (100 pF/m)
	• Pilot valve	Max. 3 m (100 pF/m)
	• Ignition transformer	Max. 3 m (100 pF/m)
	• Other lines	Max. 3 m (100 pF/m)

¹⁾ Do not run the cable together with other cables. If not observed, hum voltage might cause electromagnetic interference

Specification as per EN 60730-1:2016

Type of shutdown or interruption of each circuit

Shutdown with microswitch 1-pole

Mode of operation Type 2 B

Cross-sectional areas The cross-sectional areas of the mains power lines (L, N, and PE) and, if required, the safety loop (safety limit thermostat, water shortage, etc.) must be sized for rated currents according to the selected external primary fuse. The cross-sectional areas of the other cables must be sized in accordance with the internal unit fuse (max. 6.3 AT).

Min. cross-sectional area	0.75 mm ² (single- or multi-core as per VDE 0100)
---------------------------	---

Cable insulation must meet the relevant temperature requirements and environmental conditions.

Fuses (F1) used inside the LMV27	6.3 AT (IEC 60127 2:2014)
----------------------------------	---------------------------

Electrical connections of actuators

The fixed connected actuator cables must not be extended.

AGV50 signal cable AZL2 → BCI

Signal cable	Color white Unshielded Conductor 4 x 0.141 mm ² With RJ11-plug
Cable length	
- AGV50.100	1 m
- AGV50.300	3 m
Location	Under the burner hood (extra measures required for SKII EN 60730-1:2016)

Technical Data (cont'd)

Environmental conditions

Storage	EN 60721-3-1:1997
Climatic conditions	Class 1K3
Mechanical conditions	Class 1M2
Temperature range	-20...+60 °C
Humidity	<95 % r.h.
Transport	EN 60721-3-2:1997
Climatic conditions	Class 2K2
Mechanical conditions	Class 2M2
Temperature range	-30...+60 °C
Humidity	<95 % r.h.
Operation	EN 60721-3-3:1995 + A2:1997
Climatic conditions	Class 3K3
Mechanical conditions	Class 3M3
Temperature range	-20...+60 °C
Humidity	<95 % r.h.
Installation altitude	Max. 2,000 m above sea level



Caution!

Condensation, formation of ice and ingress of water are not permitted!

Technical Data (cont'd)

Flame supervision with ionization probe

No-load voltage at ION terminal
(X10-05 pin 2)

Approx. U_{Mains}



Caution!
Protect the ionization probe against electric shock hazard!

Short-circuit current	Max. AC 1 mA
Required detector current	Min. DC 2.3 μ A, flame display approx. 30 %
Possible detector current	Max. DC 12...30 μ A, flame display approx. 100 %
Max. perm. length of detector cable (laid separately)	3 m (wire-ground 100 pF/m)



Warning!
Simultaneous operation of QRA and ionization probe is not permitted!



Note

The higher the detector cable's capacitance (cable length), the more voltage at the ionization probe, and thus the detector current, drops. Long cable lengths plus very highly resistive flames might necessitate low-capacitance detector cables (e.g. ignition cable). In spite of technical measures taken in the circuitry aimed at compensating potential adverse effects of the ignition spark on the ionization current, it must be made certain that the minimum detector current required will already be reached during the ignition phase. If this is not the case, the connections on the primary side of the ignition transformer must be changed and / or the electrodes relocated.

Threshold values when flame is supervised by an ionization probe:

- Start prevention (extraneous light) Flame intensity (parameter 954) ≥ 18 %
- Operation Flame intensity (parameter 954) > 24 %

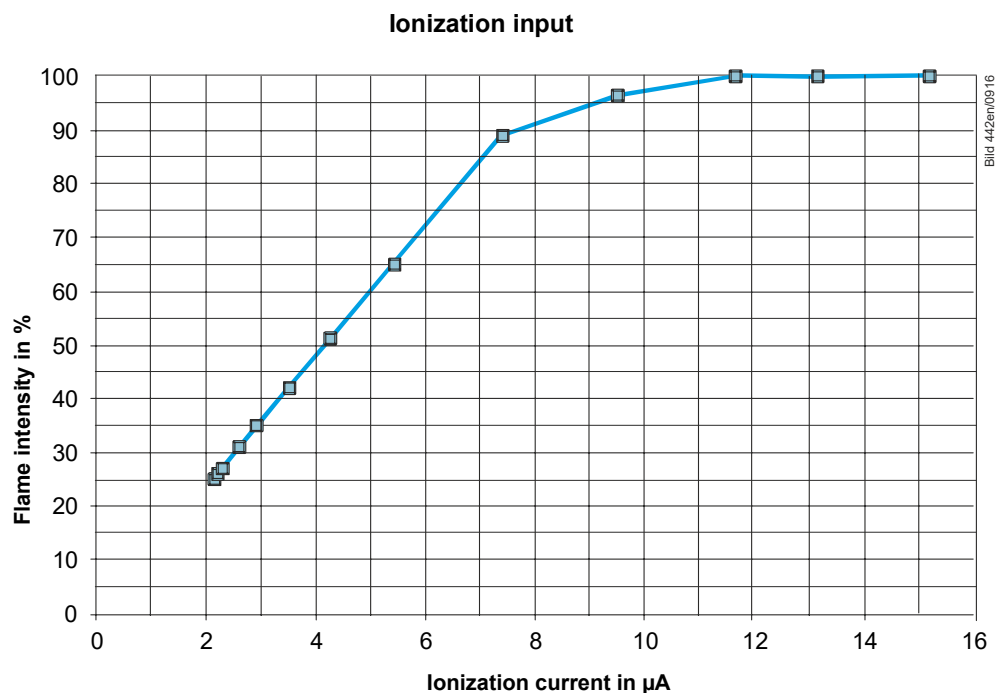

Technical Data (cont'd)

Measuring circuit for detector current measurement

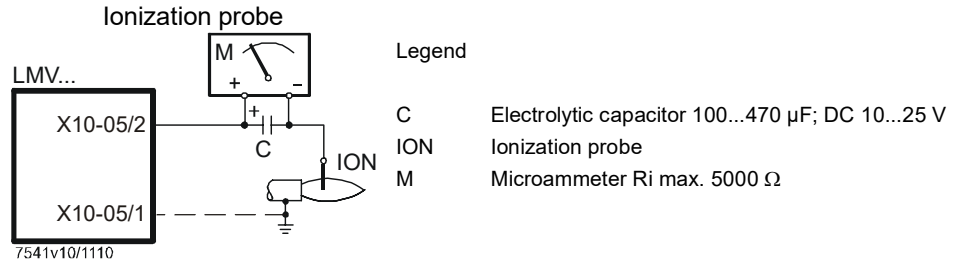

Flame supervision with QRA2 / QRA4 / QRA10



Warning!

If UV flame detectors QRA2 / QRA4 / QRA10 are used for flame supervision with the LMV27, it must be ensured that the basic unit is permanently connected to power (conforming to DIN EN 298), thus enabling the system to detect flame detector failures during startup and shutdown. Generally, the LMV27 works with QRA flame detectors in intermittent operation. *Technical Data* refer to Data Sheet N7712 covering UV flame detectors QRA2 / QRA10! *Technical Data* refer to Data Sheet N7711 covering UV flame detectors QRA4!

Operating voltage	Max. 350 V peak
Required detector current in operation	Min. 30 µA
Possible detector current in operation	Max. 600 µA
Permissible length of flame detector cable, normal cable (laid separately)	Max. 6 m
Threshold values when flame is supervised by QRA:	
- Start prevention (extraneous light)	Flame intensity (parameter 954) ≥18 %
- Operation	Flame intensity (parameter 954) >24 %

Measuring circuit for detector current measurement

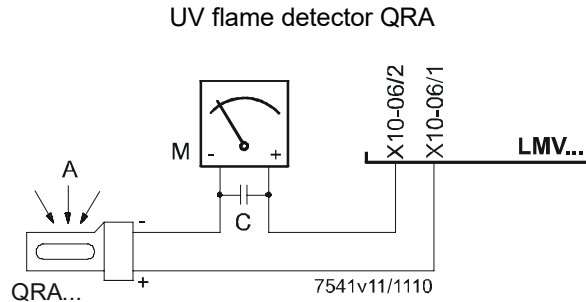

Warning!

- Input QRA is not short-circuit-proof!
Short-circuits of X10-06 pin 2 against earth can destroy the QRA input
- Simultaneous operation of QRA and ionization probe is not permitted!



Technical Data (cont'd)

Flame supervision with QRB1 / QRB3

No-load voltage at QRB1 / QRB3 terminal (X10-05 pin 3)	Approx. DC 5 V
Max. perm. length of QRB1 / QRB3 detector cable (laid separately)	3 m (wire – wire 100 pF/m)



Note

A detector resistance of $R_F < 500 \Omega$ is identified as a short-circuit and leads to safety shutdown in operation as if the flame had been lost.

For this reason, before considering the use of a highly sensitive photoresistive detector (QRB1B or QRB3S), it should be checked whether this type of flame detector is indeed required! Increased line capacitance between QRB1 / QRB3 connection and mains live wire L has an adverse effect on the sensitivity and increases the risk of damaged flame detectors due to overvoltage. Always run detector cables separately!

Threshold values when flame is supervised by QRB1 / QRB3:

Start prevention (extraneous light) with R_{QRB}	Approx. 400 k Ω Flame intensity $\geq 10 \%$
Operation with R_{QRB}	Approx. 230 k Ω Flame intensity $> 16 \%$
Short-circuit detection with R_{QRB}	$< 0,5 \text{ k}\Omega$

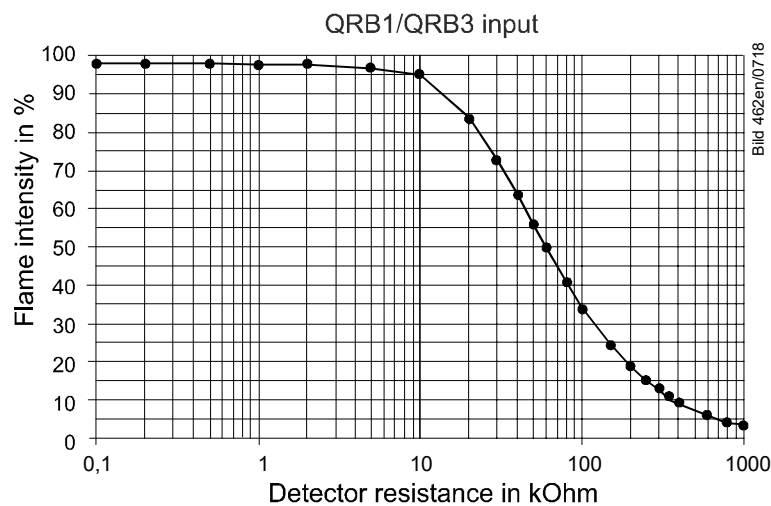

A flame detector resistance of $R_F < 500 \Omega$ is identified as a short-circuit and leads to safety shutdown in operation, like in the case of loss of flame.



Note!

In the case of the QRB1/QRB3, the maximum intensity display is limited to approximately 40% due to the system (parameter 954).

Technical Data (cont'd)

Flame supervision with QRB4

Open-circuit voltage at terminal QRB4 (X10-05 pin 3)	Approx. 5 V DC
Permissible length of QRB4 detector cable (laid separately)	3 m (wire to wire 100 pF/m)
Threshold values when flame is supervised by QRB4	
Start prevention (extraneous light)	Flame intensity (parameter 954) $\geq 10\%$
Operation	Flame intensity (parameter 954) $> 16\%$



Note!

In the case of the QRB4, the maximum intensity display is limited to approximately 40% due to the system (parameter 954).



Note!

Connection of QRB4 cables!

Blue cable of QRB4 to terminal X10-05 pin 4.
Black cable of QRB4 to terminal X10-05 pin 3.
Otherwise, the QRB4 will not work.

Technical Data (cont'd)

Flame supervision with QRC

Check the intensity of flame with the AZL2.

For system-specific reasons, the display of maximum flame intensity by the AZL2 of maximum intensity is limited to approx. 55 %.



Warning!

Flame detectors QRC are only suited for AC 230 V operation.

Start prevention (extraneous light) with IQRC	Ca. 15 μ A, display approx. 10 % Flame intensity (parameter 954)
Operation with IQRC	Ca. 25 μ A, display approx. 16 % Flame intensity (parameter 954)

	Required detector current (with flame)	Permissible detector current (without flame)	Typical detector current (with flame)
QRC	Min. 70 μ A	Max. 5.5 μ A	100 μ A

The values given in the table above only apply under the following conditions:

- Mains voltage AC 230 V
- Ambient temperature 23 °C

Measuring circuit for detector current measurement

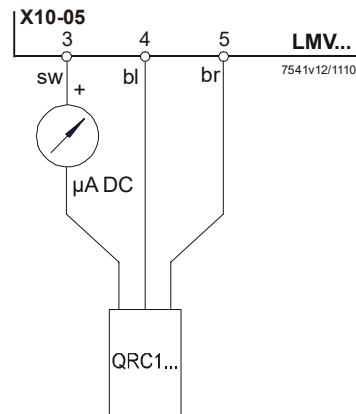

Legend

- μ A DC DC-Mikroampèremeter an internal resistance of
Ri = max. 5 k Ω
- bl blue
sw black
br brown

Dimensions

Dimensions in mm

LMV27

