

Desigo™ Room Automation

Compact actuating room automation stations, BACnet/IP, AC 24 V (Actuating DXR)

DXR1.E02PLZ-112



Combination of room automation station and actuator for buildings with increasing demand on functionality and flexibility in Room Automation, VAV applications.

- Combination of compact room automation station and actuator for VAV control
- No room unit can be connected
- BACnet IP communications (BTL certified)
- 2-port Ethernet switch
- USB interface
- Operating voltage AC 24 V
- Built-in 10 Nm actuator
- Internal 0...500 Pa differential pressure sensor
- Plug-in terminal blocks

Features

Compact series

The compact build allows direct mounting on the damper shaft.

Plug-in terminal blocks

Plug-in terminal blocks for easy exchange of room automation stations.

Integrated actuator

The actuator gear base is integrated into the housing of the actuating DXR. It supports dampers with up to 10 Nm torque.

Use

The Desigo Room Automation offers the highest level of flexibility for energy-optimized solutions while satisfying requirements for temperature control, ventilation and comfort using standard tools and established workflows.

Pre-installed application types

Variable (VAV) and constant air volume flow control

Functions

The selected application and its parameters as well as input and output configuration determine the room automation station's functionality.

A detailed description of functionality is available in the ABT (Automation Building Tool) online help.

Communication

- 2-port Ethernet switch for cost-effective cabling via line topology

Note: DXR1 supports cabling based on daisy chain topology. The max. number is 20 devices and in the event of a failed automation station, all other stations are no longer reachable. DXR1 can be cabled as ring topology if higher reliability is required. This requires support for layer 2 switches RSTP (Rapid Spanning Tree Protocol) as well as SNMP monitoring and that any loss of superposed system is reported. In the event of a fault, switching the communication paths can take between 10 and 30 seconds. DXR1 routes the RSTP protocol for the switches. It does not actually process the RSTP protocol. Further information can be found in Application Guide for BACnet Networks in Building Automation (A6V11159798).

- USB connection for service and commissioning and firmware download

LED indication

LED	Color	Activity	Function
Run	Green	Steady ON	Device is ready for operation
		Steady OFF	Device is not powered
		Regular flashing	Start-up or the program is stopped
	Red	Steady OFF	OK
		Steady ON	Program error Hardware fault
		Rapid flashing	Wrong or corrupt software No application loaded
		Blinking per wink command	Physical device identification

Service button (SVC)

Physical identification on the network.

Technical / Mechanical design

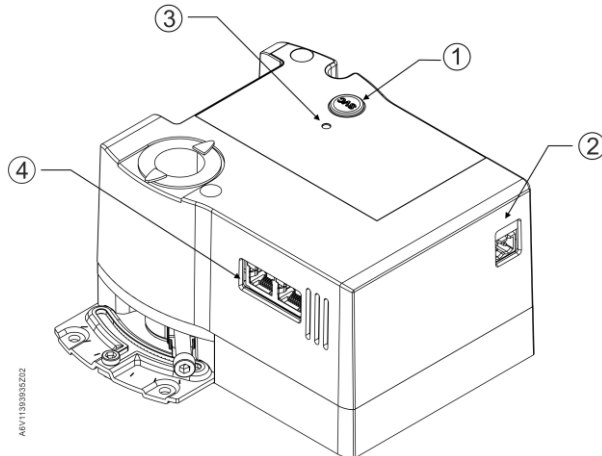

1	Service button (SVC) for sending device identification	2	Power supply
3	Status information LED (bi-color)	4	2-port Ethernet switch

Housing

The housing consists essentially of flame retardant, non-brominated plastic.

Type summary

Product no.	Stock no.	Inputs	Outputs	Description	Quantity
DXR1.E02PLZ-112	S55499-D460	-	-	VAV application	Single package / multiple package (10)

Ordering

When ordering, indicate product number, stock number and description.

Product documentation

Topic	Title	Document ID:
Installation, cable length, topology	Desigo Room Automation installation guide	CM111043
Engineering and commissioning	ABT online help	N/A
Installation instruction	Mounting instructions	A6V11393918
Commissioning	Quick guide	A6V11526405
Product environmental declaration		A6V11805930
EU declarations (CE)		A6V11791489

Documents such as environmental declarations, CE declarations, etc., can be downloaded at the following Internet address:

<http://siemens.com/bt/download>

Notes

Security

	⚠ CAUTION
	National safety regulations Failure to comply with national safety regulations may result in personal injury and property damage. <ul style="list-style-type: none">• Observe national provisions and comply with the appropriate safety regulations.• Use only properly trained technicians for mounting, commissioning and servicing.

Engineering

Identification

Each device has a unique serial number to ensure efficient commissioning. It is provided on the adhesive barcode reader. The serial number can be read directly into the engineering tool using a barcode reader.

Wiring

Wiring must be sufficiently insulated to the available rated voltage. Sizing and fusing of the wiring depends on the connected load.

Mounting

The automation station is mounted directly on a damper shaft.

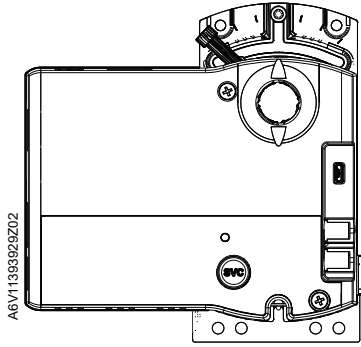

See the mounting instructions (document ID: A6V11393918) for detailed information.

Differential pressure sensor

- Avoid bends and pressure when attaching the tube.
- Connect the "+" connection on the side with the higher pressure and the "-" connection on the side with the lower pressure.
- Connection tubes (interior diameter) of 4 mm.
Air tube connection kit DXA.T50 for connection of tubes with 6.5 mm (interior diameter).
- The maximum tube length is 2 m.

Maintenance

The automation station is maintenance-free.

Disposal



The device is considered an electronic device for disposal in accordance with European Directive and may not be disposed of as domestic waste.

- Use only designated channels for disposing the devices.
- Comply with all local and currently applicable laws and regulations.

Technical data

Power data

Power supply	
Operating voltage (SELV/PELV)	AC 24 V +/-20 %
Frequency	50 or 60 Hz
Power consumption	7 VA max.

Transformer requirements and recommended voltages	
Type	Class 2, AC 24 V, 50 / 60 Hz, SELV, PELV

Functional data

Functional data	
Nominal torque	10 Nm
Nominal rotary angle	90°
Maximum rotary angle	95° ± 2°
Runtime for 90° rotary angle	150 s
Shaft size	8...16 mm, round 8...10 mm, round (with centering insert) 6...12.8 mm square
Minimum shaft length	20 mm

Pressure sensor

Pressure sensor	
Measurement range	0...500 Pa
Sample rate	≤ 500 ms
Overload range	0...100 kPa
Measuring range accuracy	3 %
Zero point accuracy	0.2 Pa
Resolution	12 Bit

Connections

Interfaces	
Ethernet	Plugs: dual RJ45, 10M/100M fast Ethernet Interface type: IEEE 802.3 compliance Cable type: 100M STP CAT 5
USB (2.0)	Type Micro B

Ambient conditions and protection classification	
Classification per IEC/EN 60730 Function of automatic control devices Pollution degree Overvoltage category	Type 1 2 III
Design type	Device suited for use with equipment of safety classes I and II
Degree of protection of housing to IEC EN 60529 Room automation station	IP20
Climatic ambient conditions Transport (packaged for transport) as per IEC EN 60721-3-2 Operation as per IEC/EN 60721-3-3	Class 2K3 Temperature -25...70 °C Air humidity 5...95 % (non-condensing) Class 3K5 Temperature -5...50 °C Air humidity 5...95 % (non-condensing)
Mechanical ambient conditions Transport as per IEC/EN 60721-3-2 Operation as per IEC/EN 60721-3-3	Class 2M2 Class 3M2

Standards, directives and approvals	
Product standard	IEC/EN 60730-1 Automatic electronic controls for household and similar use
EU conformity (CE)	A6V11791489
RCM conformity	A6V11791498
EAC conformity	Eurasian conformity
UL Approbation Federal Communications Commission	UL as per UL916, http://ul.com/database cUL as per CSA – C22.2 No. 205 FCC CFR 47 Part 15 Class B
ICES003	CAN ICES-3 (B)/NMB-3(B)
Environmental compatibility	The product environmental declaration (A6V11805930*) contains data on environmentally compatible product design and assessments (RoHS compliance, materials composition, packaging, environmental benefit, disposal).

* The documents can be downloaded from <http://siemens.com/bt/download>.

FCC regulations

Modification of this device to receive cellular radio telephone service signals is prohibited under FCC rules and federal law.

This equipment has been tested and found to comply with the limits for a Class B digital device, pursuant to part 15 of the FCC Rules. These limits are designed to provide reasonable protection against harmful interference in a residential installation. This equipment generates, uses and can radiate radio frequency energy and, if not installed and used in accordance with the instructions, may cause harmful interference to radio communications. However, there is no guarantee that interference will not occur in a particular installation. If this equipment does cause harmful interference to radio or television reception, which can be determined by turning the equipment off and on, the user is encouraged to try to correct the interference by one or more of the following measures:

Reorient or relocate the receiving antenna.

Increase the separation between the equipment and receiver.

Connect the equipment into an outlet on a circuit different from that to which the receiver is connected. Consult the dealer or an experienced radio/TV technician for help.

Changes or modifications not expressly approved by the party responsible for compliance could void the user's authority to operate the equipment.

Statement

This device complies with part 15 of the FCC Rules. Operation is subject to the following two conditions: (1) This device may not cause harmful interference, and (2) this device must accept any interference received, including interference that may cause undesired operation.

General

General information	
Color	Light gray
Dimensions	L × W × H = 137 × 143 × 82 mm
Weight	Net weight: 614.1 g Gross weight: 817.3 g

Connection terminals

DXR1.E02PLZ-112

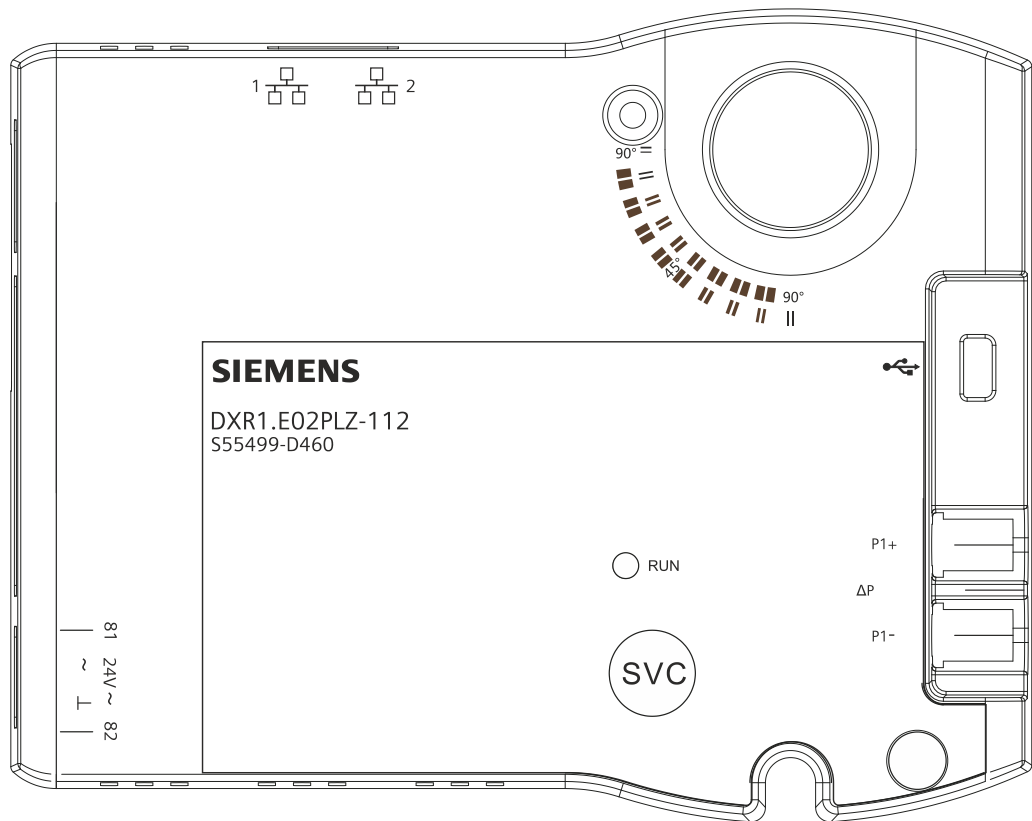

A6V11393935Z01

Pin	Description	Terminal
1, 2	IP connection	
USB	USB interface	
81, 82 power 24 V~	Power supply AC 24 V	V~
	System neutral (must always be grounded at the transformer)	⊥
ΔP differential pressure detector	Connected to the higher pressure	P1+
	Connected to the lower pressure	P1-
Service	Service button	SVC
Display	Operation LED	RUN

Dimensions

Dimensions in mm

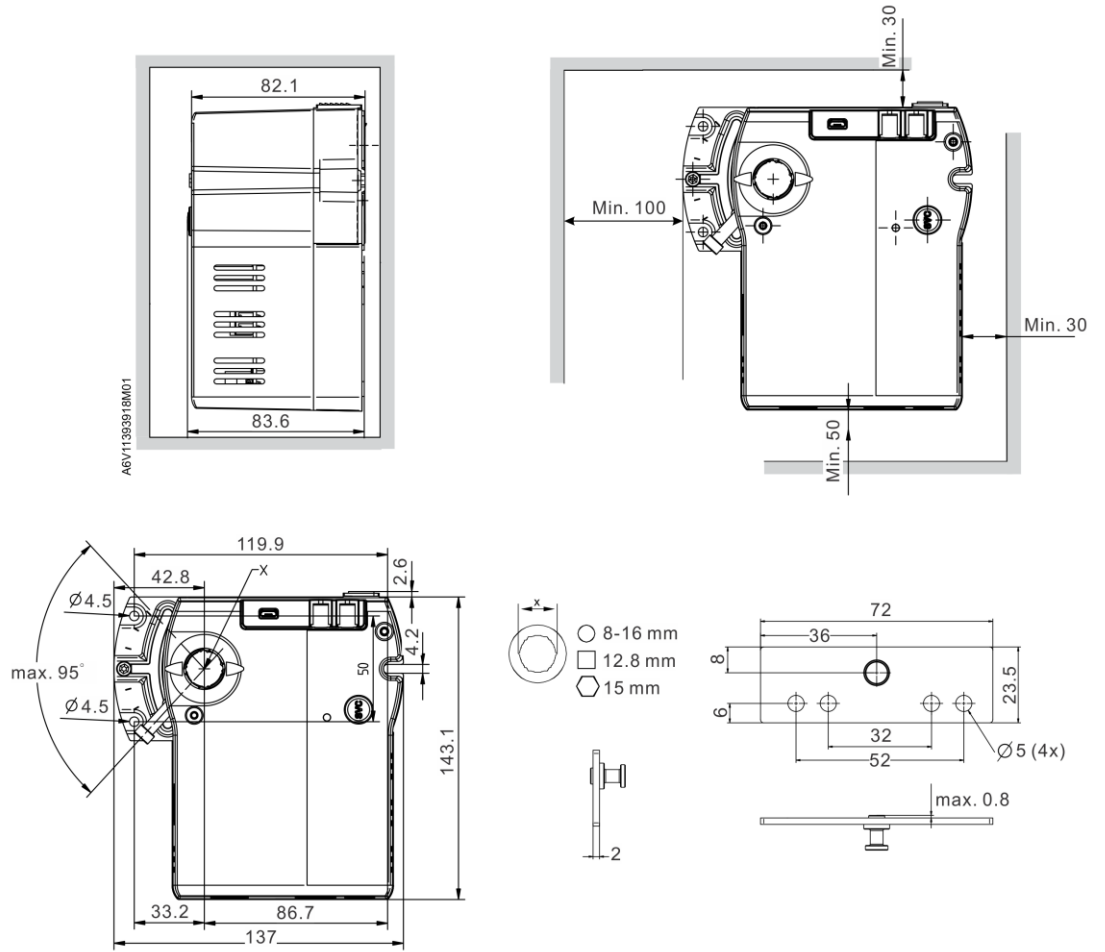

Issued by
Siemens Switzerland Ltd
Smart Infrastructure
Global Headquarters
Theilerstrasse 1a
CH-6300 Zug
+41 58 724 2424
www.siemens.com/buildingtechnologies

© Siemens Switzerland Ltd, 2021
Technical specifications and availability subject to change without notice.

Document ID A6V11393935_en--_d
Edition 2021-08-26